

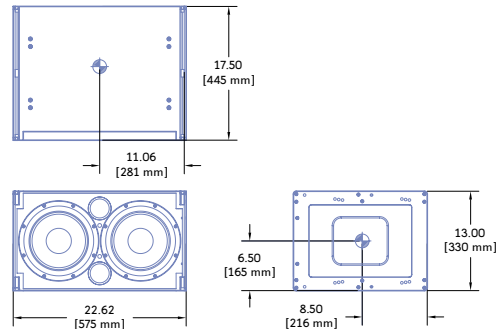

M1D™-SUB : Ultra-Compact Subwoofer

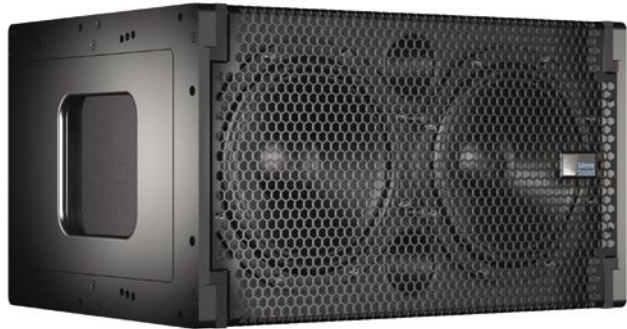

Dimensions	22.62" W x 13.00" H x 17.50" D (575 mm x 330 mm x 445 mm)
Weight	70 lbs (31.75 kg); shipping: 75 lbs (15.88 kg)
Enclosure	Multi-ply hardwood
Finish	Black textured
Protective Grille	Powder-coated hex stamped steel
Rigging	QuickFly® MRF-1D-Sub rigging frame

The M1D-Sub ultra-compact subwoofer complements the M1D ultra-compact curvilinear array loudspeaker by extending bandwidth with its operating frequency range of 32 Hz - 180 Hz and substantially increasing overall system headroom. Because it produces a prodigious peak SPL of 130 dB at 1 meter from a compact cabinet, the M1D-Sub allows system designers to minimize array size while maximizing system response. A variety of QuickFly rigging options allows the M1D-Sub to be flown above, below or within an array, or placed at the base of a ground-stacked array. Although it is intended primarily as a companion subwoofer to the M1D, it is perfectly suited to general use where powerful low frequency augmentation is desired.

M1D-Sub contains two robust 10-inch cone drivers, each featuring a 2-inch voice coil and a lightweight neodymium magnet structure. Power rating per driver is 400 AES watts (see note 5 on back page). A fully

integrated and self-powered system, the M1D-Sub also incorporates a two-channel class AB/bridged complementary MOSFET amplifier with 450 watts total burst capability. An Intelligent AC power supply selects the correct operating voltage in the range of 90 to 264 V AC at 50 or 60 Hz, allowing international use without manually setting voltage switches. The Intelligent AC supply also performs protective functions to compensate for hostile conditions on the AC mains. These functions protect both the loudspeaker and electronics from erratic AC conditions and increase the lifespan of the loudspeaker. An ultra-low-noise fan is fitted, but cooling is primarily provided by a massive external extruded aluminum heat sink.

The vented M1D-Sub cabinet is constructed of multi-ply hardwood with a durable finish suited to touring or installed use. A metal grille protects the drivers.

M1D-Sub features Meyer Sound's QuickFly rigging system with rugged, reliable and deceptively simple components. All load stresses are transmitted through the rigging frames and associated hardware, not through the wooden cabinets. The optional QuickFly MG-1D multipurpose grid allows either flying or ground stacking various combinations of M1D and M1D-Sub. Up to 16 M1Ds (or the equivalent weight of M1D and M1D-Sub) with a 7:1 safety factor may be flown, or up to 8 M1Ds or 4 M1D-Subs may be ground stacked. For flying only, the simpler optional MTG-1D will support up to 16 M1Ds (or the equivalent weight of M1D and M1D-Sub) with a 7:1 safety factor.

The M1D-Sub includes Meyer Sound's RMS™ monitoring system as standard. RMS allows the full range of operating parameters to be monitored in real time, remotely over a network using a Windows® computer.

FEATURES & BENEFITS

- Extremely compact and lightweight
- High power-to-size ratio for maximum installation flexibility
- Exceptional fidelity and peak capability assure clean, high-impact lows

- QuickFly rigging system simplifies use in flown or ground-stacked arrays
- Seamless integration with M1D loudspeakers

APPLICATIONS

- Theatrical sound reinforcement
- Houses of worship
- Portable and installed audio-visual systems
- Surround playback systems

M1D-SUB SPECIFICATIONS

ACOUSTICAL¹		Operating Frequency Range² 32 Hz – 180 Hz Frequency Response³ 35 Hz – 160 kHz ±4 dB Phase Response 50 Hz – 120 kHz ±45° Maximum Peak SPL⁴ 130 dB Dynamic Range >110 dB
COVERAGE		Horizontal Coverage 360° Vertical Coverage Varies, depending on array length and configuration
TRANSDUCERS		Low Frequency Two 10" cone drivers with neodymium magnets Nominal impedance: 4 Ω Voice coil size: 2" Power-handling capability: 400 W (AES) ⁵
AUDIO INPUT		Type Differential, electronically balanced Maximum Common Mode Range ±15 V DC, clamped to earth for voltage transient protection Connectors Female XLR input with male XLR loop output Input Impedance 10 kΩ differential between pins 2 and 3 Wiring Pin 1: Chassis/earth through 220 kΩ, 1000 pF, 15 V clamp network to provide virtual ground lift at audio frequencies Pin 2: Signal + Pin 3: Signal – Case: Earth ground and chassis DC Blocking Differential DC blocking up to maximum common mode voltage CMRR >50 dB, typically 80 dB (50 Hz – 500 Hz) RF Filter Common mode: 425 kHz Differential mode: 142 kHz TIM Filter Integral to signal processing (<80 kHz) Nominal Input Sensitivity 0 dB V (1 V rms, 1.4 V pk) continuous is typically the onset of limiting for noise and music Input Level Audio source must be capable of producing a minimum of +20 dB V (10 V rms, 14 V pk) into 600 Ω in order to produce maximum peak SPL over the operating bandwidth of the loudspeaker
AMPLIFIERS		Type Two-channel complementary MOSFET output stages (class AB/bridged) Output Power⁶ 450 W total THD, IM, TIM <.02 % Load Capacity 4 Ω each channel Cooling Forced air cooling over amplifier heatsink
AC POWER		Connector PowerCon with looping output Automatic Voltage Selection Automatic Safety Agency Rated Operating Range 100 – 240 V AC; 50/60 Hz Turn-on and Turn-off Points⁷ Continuous 90 – 264 V AC; 50/60 Hz Current Draw⁸: Idle Current 0.41 A rms (115 V AC); 0.33 A rms (230 V AC); 0.42 A rms (100 V AC) Max Long-Term Continuous Current (>10 sec) 3.2 A rms (115 V AC); 1.6 A rms (230 V AC); 3.7 A rms (100 V AC) Burst Current (<1 sec) 5.0 A rms (115 V AC); 2.5 A rms (230 V AC); 5.8 A rms (100 V AC) Ultimate Short-Term Peak Current Draw 17 A pk (115 V AC); 8.5 A pk (230 V AC); 20 A pk (100 V AC) Inrush Current 15 A pk (115 V AC); 13 A pk (230 V AC); 15 A pk (100 V AC)
RMS NETWORK		Equipped for two conductor twisted-pair network, reporting all operating parameters of amplifiers to system operator's host computer.

NOTES:

- The low-frequency power response of the system will increase according to the length of the array.
- Recommended maximum operating frequency range. Response depends on loading conditions and room acoustics.
- Free field, measured with 1/3 octave frequency resolution at 4 meters.
- Measured with music at 1 meter.
- Power handling is measured under AES standard conditions: transducer driven continuously for two hours with band-limited noise signal having a 6 dB peak-average ratio.
- Amplifier wattage rating based on the maximum unclipped burst sine-wave rms voltage that the amplifier will produce into the nominal load impedance. Both channels: 30 V rms (42 V pk).
- No automatic turn-off voltages. Voltages above 264 V AC are fuse protected but may cause permanent damage to the power supply. Voltages below 90 V AC may result in intermittent operation.
- Current draw for a single loudspeaker. Loop out not used.



M1D-SUB - 04.116.001.01

MEYER SOUND LABORATORIES INC.
 2832 San Pablo Avenue
 Berkeley, CA 94702

T: +1 510 486.1166
 F: +1 510 486.8356

techsupport@meyersound.com
 www.meyersound.com

Copyright © 2003
 Meyer Sound Laboratories Inc.
 All rights reserved

ARCHITECT SPECIFICATIONS

The loudspeaker shall be a self-powered, sub-bass system that may be deployed as part of a flown array or placed separately in proximity to the mid-high M1D array. The transducers shall consist of two 10-inch cone drivers (2-inch voice coil) each rated to handle 400 AES* watts.

The loudspeaker shall incorporate internal processing electronics and a two-channel amplifier. Each amplifier channel shall be class AB/bridged with complementary MOSFET output stages. Burst capability shall be 450 watts total with nominal 4-ohm resistive load on each channel. Distortion (THD, IM, TIM) shall not exceed 0.02%. Protection circuits shall include peak and rms limiting. The audio input shall be electronically balanced with a 10 kOhm impedance and accept a nominal 0 dBu (1 V rms, 1.4 V pk) signal (+20 dBV to produce maximum SPL). Connectors shall be XLR (A-3) type male and female. RF filtering shall be provided, and CMRR shall be greater than 50 dB (80 dB 50 – 500 Hz).

Performance specifications for a typical production unit shall be as follows, measured at 1/3 octave resolution: Operating frequency range shall be 32 Hz to 180 Hz. Phase response shall be ±45° from 35 Hz to 160 Hz. Maximum SPL shall be 130 dB at 1 meter. Coverage shall be 360° horizontal. (Vertical varies with array configuration.)

The internal power supply shall perform automatic voltage selection, EMI filtering, soft current turn-on and surge suppression. Powering requirements shall be 90 to 264 V AC line current at 50 Hz or 60 Hz. UL and CE operating voltage range shall be 100 V AC to 240 V AC. Current draw during burst shall be 5 A at 115 V AC and 2.5 A at 230 V AC. Inrush current during turn-on shall not exceed 15 A at 115 V. AC power connectors shall be locking PowerCon with loop output.

The loudspeaker system shall incorporate the electronics module for Meyer Sound's RMS remote monitoring and control system.

All loudspeaker components shall be mounted in an enclosure constructed of multi-ply hardwood with a black textured finish. The front protective grille shall be powder-coated, hex stamped steel. Dimensions shall be 22.62" wide x 13" high x 17.50" deep (575 mm x 330 mm x 445 mm). Weight shall be 70 lbs (31.75 kg).

The loudspeaker shall be the Meyer Sound Model M1D-Sub.

*Driven continuously for two hours with band-limited noise signal having a 6 dB peak-average ratio.